

Section 1. General Specifications

Content		Unit	Specification
Compressor Model		—	C-SBP140H16A
Type		—	Hermetic Scroll Compressor
Application		—	High Back Pressure
Evap. Temp. Range		°C (°F)	-15~12 (5~54)
Compressor Cooling Type		—	Natural Cooling
Power Source	Phase	—	1
	Rated Voltage	V	208-230
	Rated Frequency	Hz	60
Voltage Range		V	187-253
Weight (Including Oil)		kg (lb)	40 (88.2)
Refrigerant		—	R410A
Oil Type		—	FV68S or Equivalent
Oil Charge		ml (fl oz)	1400 (47.3)
Displacement		cm ³ (in ³) /rev	46.35(2.83)
Motor	Motor Type	—	1-PH Induction Motor (PSC)
	Number of Poles	—	2
	Electrical Insulation	Class	E
	Nominal Revolution	min ⁻¹	3500
	Locked Rotor Ampere	A	139
	Winding Resistance [at 25°C (77°F)]	Ω	C-S 0.755 C-R 0.368
Connection Tube	Suction Line (O.D.)	mm (in)	22.2 (0.875)
	Discharge Line (O.D.)	mm (in)	12.7 (0.500)
Compressor Surface Paint		—	Black Paint
Capacitor		—	60-440

Notes

- 1 Voltage range is applied at standard rating conditions.
- 2 Motor specifications in the table are the average values for your reference.
- 3 (): All units with parentheses are reference values.

Expiration of Specification

Expiration of this specification shall be effected until issuing a notice with indication of the expiration date from the issued date. In case of improvement or elimination of this specification, it shall be handled by the revision record based on agreement between both sides.

Section 2. Performance Warranty

2.1 Performance

Power Source (1PH)	Hz	60	60	Remark
	V	208	230	
Capacity	W	14,200	14,300	±5%
	(BTU/hr)	48,450	48,792	reference
Input Power	W	4,950	4,950	±5%
Current	A	24.50	22.30	±5%

Standard Rating Conditions

Condensing Temp.	°C (°F)	54.4(130)
Evaporating Temp.	°C (°F)	7.2(45)
Suction Gas Temp.	°C (°F)	18.3(65)
Liquid Temp.	°C (°F)	46.1(115)
Ambient Temp.	°C (°F)	35(95)

Parts Name	Specification
Running Capacitor	60μ F 440V

Note: A starting capacitor of 100~140μF/330V (Bleed Resistor:Rf=18kΩ , 2W) could be used in special difficulty starting case.

Notes

- 1 Installation should be completed within 15 minutes after removing the rubber plugs.
- 2 Do not use the compressor to compress air.
- 3 Do not energize the compressor under vacuumed condition.
- 4 Evacuation and Refrigerant charge : Evacuate internal section in the refrigeration system from high and low pressure sides and charge liquid refrigerant from condenser outlet side. Additional charge shall be done with gas condition from low side.
- 5 Do not tilt over the compressor while carrying it.
- 6 Do not remove the paint.
- 7 Crankcase heater is required when the oil sump temperature is too low to meet the requirement of item 6 on page7.
- 8 Voltage fluctuation between compressor terminals, during operation, shall be within 2% of the rated voltage.
- 9 Do not operate compressor in reverse rotational direction.
- 10 Suction strainers are recommended for all applications.

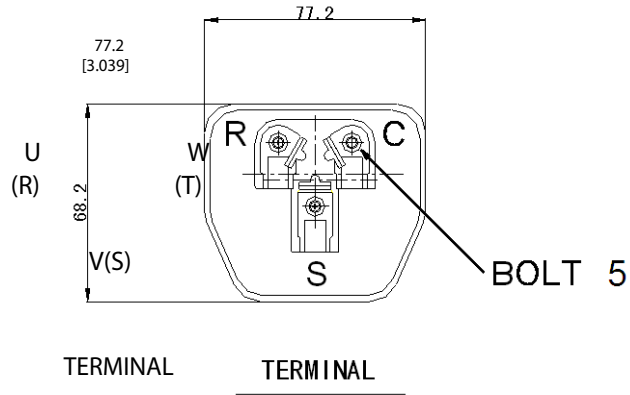
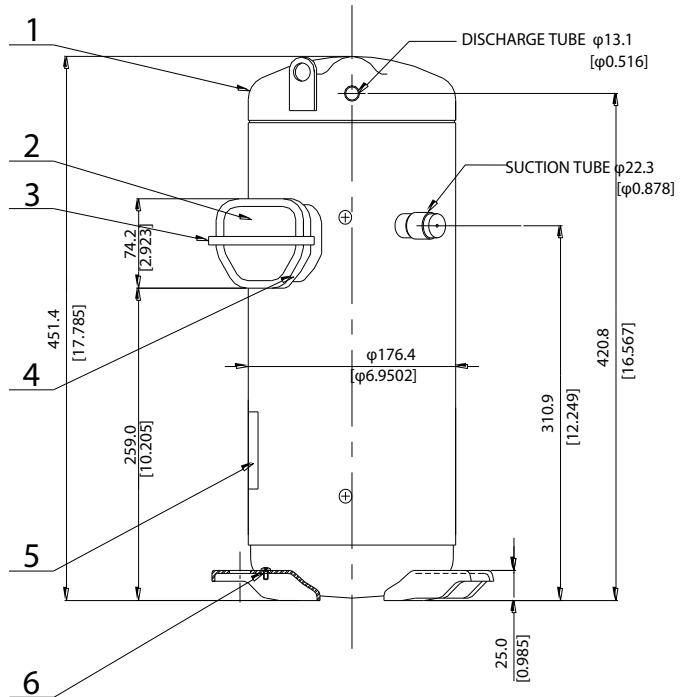
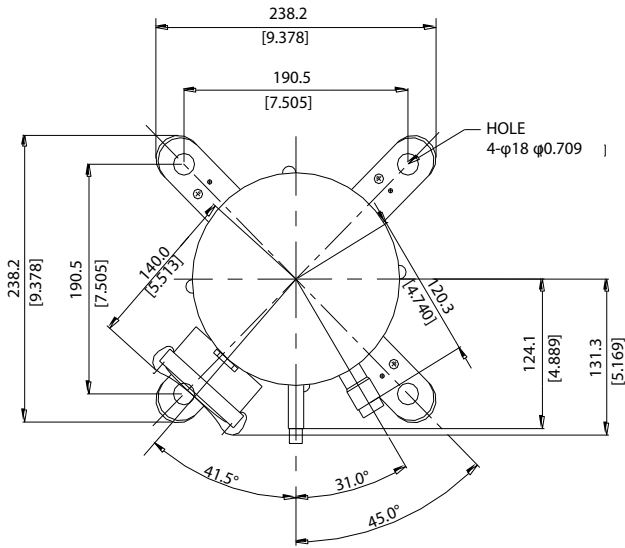

No.	Part Code	Qty	Name
1	C-SBP140H16A	1	Compressor
2	A-0101-DSB	1	Terminal Box Cover
3	A-0201-DSB	1	Terminal Box Clip
4	A-0301-DSB	1	Eyelet Rub Lead Wire
5		1	Nameplate
6	B-0101-DSB	1	Screw Special

Part Code
D-0109-DSB

PartsConnect

Name
Compressor Outline Drawing

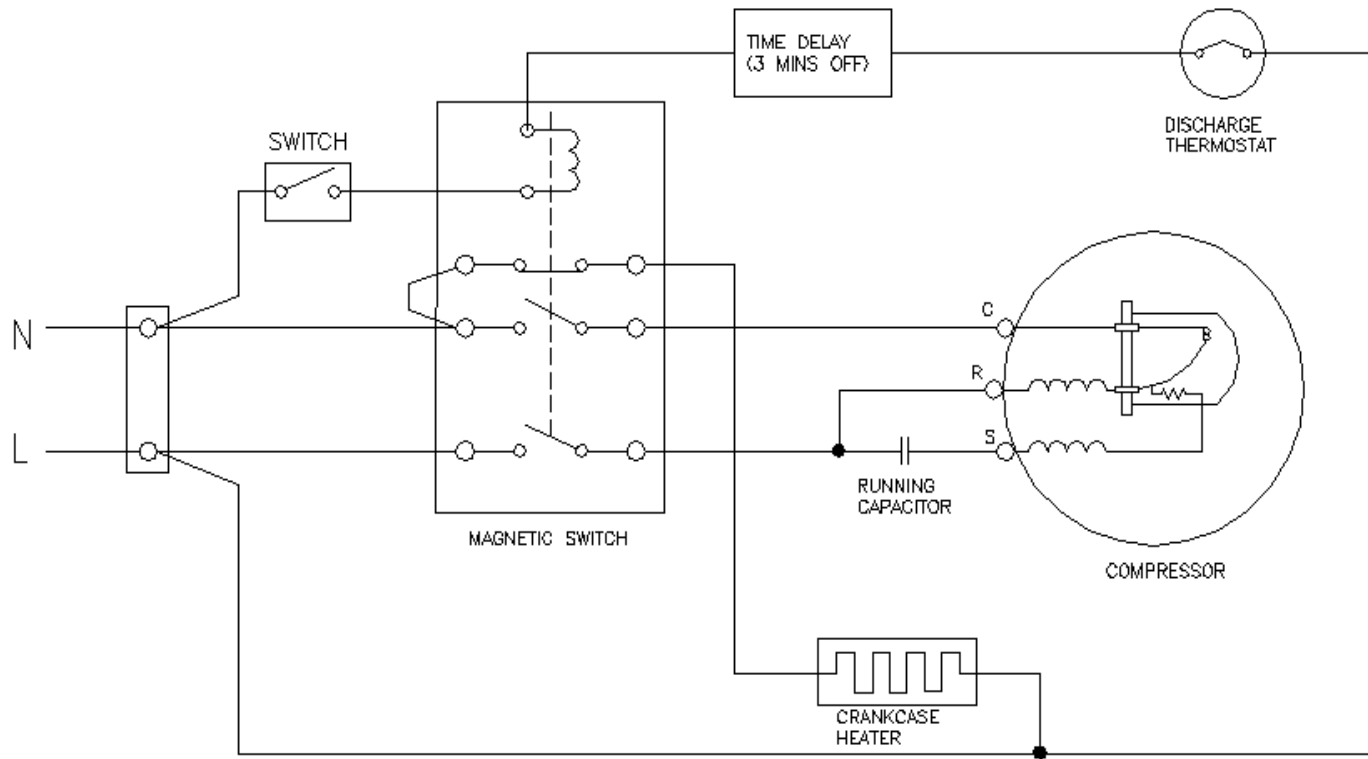

Part Code
E-0916-DSB
Name
Wiring Diagram